

LINE-VOLTAGE PENDANTS/SUSPENSION

Sara Grande Pendant

DESCRIPTION

Pure indulgence, the Sara Grande is cut from a solid block of crystal and formed into an elegant cylinder which surrounds a hand-blown inner white glass diffuser. Instantly elevates any space. Black, satin nickel, with antique bronze detail and brown cable. Includes 120 volt, 60 watt or equivalent medium base BT15 lamp or 26 watt GX24Q-3 base triple tube compact fluorescent lamp (electronic ballast included). May also be lamped with GX24Q-3 base 32 watt triple tube compact fluorescent lamp (not included). Fixture is provided with six feet of field-cutable cable. Incandescent version dimmable with standard incandescent dimmer.

INSTALLATION

This product can mount to either a 4" square electrical box with round plaster ring or an octagon electrical box.

WEIGHT

5.62lb / 2.55kg ±

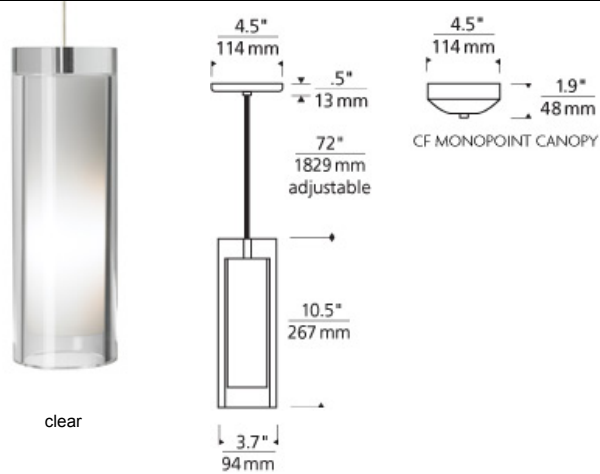

* Also available in 2.6" diam x 5.9" H (35watt bi-pin halogen lamp included).

ORDERING INFORMATION

700 SYSTEM	SARGP	COLOR	FINISH	LAMP
TD	LINE-VOLTAGE PENDANTS/SUSPENSION	C CLEAR	Z ANTIQUE BRONZE B BLACK S SATIN NICKEL W WHITE	INCANDESCENT 120V -CF COMPACT FLUORESCENT 120V -CF277 COMPACT FLUORESCENT 277V

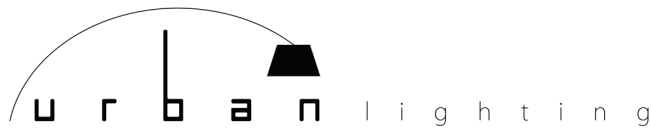

619.232.6064 | sales@urbanlighting.net | 301 4th Avenue | San Diego, CA 92101



©2015 Tech Lighting, L.L.C. All Rights Reserved. The "Tech Lighting" graphic is a registered trademark of Tech Lighting, L.L.C. Tech Lighting reserves the right to change specifications for product improvements without notification.