



shown in Textured Bronze



shown in Polished Chrome



shown in Brushed Nickel

Irene-3

Designed in 2013

Cutting a figure like no other, the Irene-3 is rustic, yet strikingly modern.

Irene-3 is inspired by the golden age of aviation with three neatly joined propeller-shaped, solid walnut-stained wooden blades. A spherical motor housing complements its minimal profile. Irene-3 is streamline while still appearing warm and natural.

- 52" diameter with three solid wood, walnut-stained machine-cut blades.
- Energy efficient six speed, reversible DC motor with new, reliable technology.
- Damp location finishes: brushed nickel, polished chrome or textured bronze.
- Constructed of cast aluminum and heavy stamped steel.
- Limited Lifetime Warranty
- Standard equipment:
 - One downrod of 10". 5", 20", 30", 48" or 72" downrods are also available.
 - Vaulted ceiling mount canopy for up to 30 degrees.
 - Reverse on six-speed, hand-held and wall-mountable remote control.

MATTHEWS

FAN COMPANY



Irene-3

weight: 17 lbs

voltage: 110*

*Please contact us for possible 220 conversion

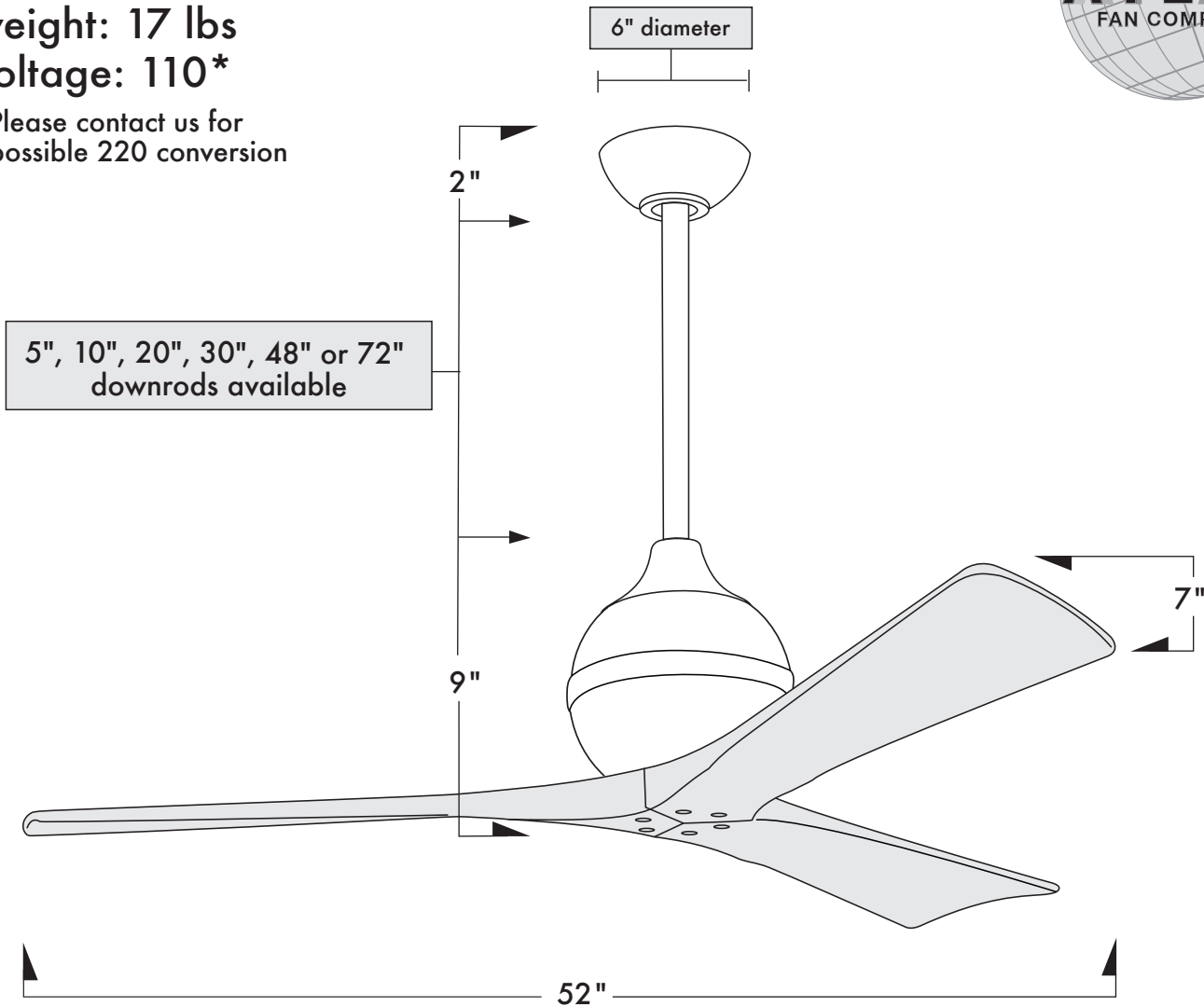

SKU Naming Convention	
IR3-XX (Model-Finish)	
Finishes	
Brushed Nickel	- BN
Polished Chrome	- CR
Textured Bronze	- TB

CFM
6355



The Irene-3 is compatible with flat or vaulted ceilings and can be mounted with any one of the following downrod lengths: 5", 10", 20", 30", 48" and 72".



**Damp location with powder or clear coat only. Not recommended for salt water/ocean front applications.