



# Eliza

Geometry in Motion

Designed in 2013



Designed by Chicago architect Stephen Katz in 2013, this fan blends a beautiful technically derived form with superior function and movement. The unique blade shape is designed to maximize air movement at the outer edge of the blade. The result is more efficient air velocity rings, less blade drag and greater motor optimization. Equally important is the Eliza fan's stationary visual statement which combines modern utility with minimalist geometry.

- 56" diameter.
- Energy efficient, ultra-quiet, six-speed and reversible DC motor with new reliable technology.
- Damp location finishes: brushed nickel and gloss white.
- Constructed of cast aluminum, polycarbonate and heavy stamped steel.
- Limited Lifetime Warranty
- Standard equipment:
  - One downrod of 10". 5", 20", 30", 48" or 72" downrods also available.
  - Vaulted ceiling mount canopy for up to 30 degrees.
  - Reverse on six-speed, hand-held and wall-mountable remote control.



# MATTHEWS

FAN COMPANY



## Eliza

weight: 17 lbs  
voltage: 110\*

\*Please contact us for possible 220 conversion

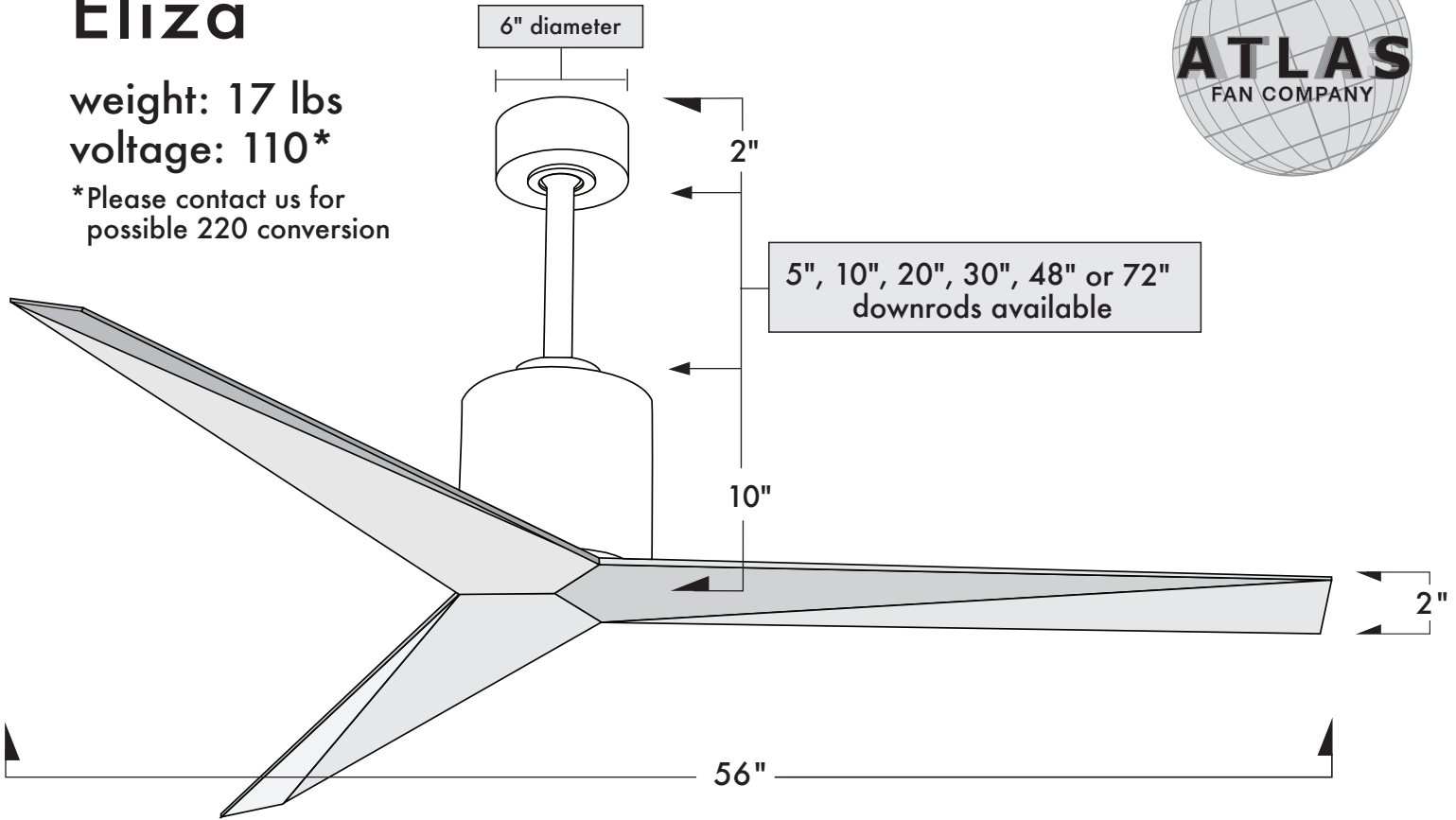

SKU Naming Convention	
EK-XX (Model-Finish)	
Finishes	
Brushed Nickel	- BN
Gloss White	- WH

CFM
5396

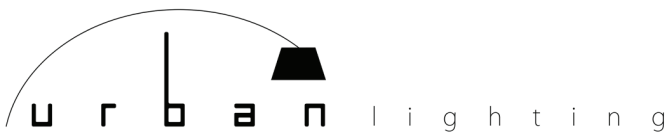

619.232.6064 | sales@urbanlighting.net | 301 4th Avenue | San Diego, CA 92101



The Eliza is compatible with flat or vaulted ceilings and can be mounted with any one of the following downrod lengths: 5", 10", 20", 30", 48" and 72".



\*\*Damp location with powder or clear coat only. Not recommended for salt water/ocean front applications.