

CLAMP  
DESIGN: DANA CAHNAM

Pablo

Pablo®  
CLAMP

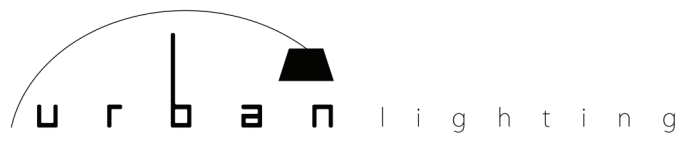

# CLAMP

## DESCRIPTION

Designed for simplicity and engineered for sustainability, Clamp combines the beauty of wood with the brilliance of LED technology. Clamp's minimal components work together to provide infinite adjustment, while focusing warm, diffused light where needed most. Available in clamp mount, freestanding, mini and floor models in White Oak and Walnut.

## DESIGNER

Dana Cannam 2011 - 2013

## MATERIALS

- Wood lamp assembly
- Polyurethane bushings
- Polycarbonate lens
- Fabric cord
- Leather clamp pad (Clamp only)
- ABS cover (Clamp FS only)
- Steel base weight (Clamp FS, Mini and Floor only)
- Brass washer (Clamp Floor only)

## FEATURES

- 360° arm rotation
- Advanced LED array eliminates multiple shadows
- Hi-low dim control
- Ships flat-packed

## SPECIFICATIONS

- Voltage: 120/220V 60Hz
- Power Consumption: 9W (Clamp Mini: 6W)
- Color temperature: 3000K
- Luminosity: 485 Lumens (Clamp Mini: 325 Lumens)
- Luminaire efficacy: 55 Lumens/Watt
- Color Rendition Index: 85 CRI
- 50K hour lifespan
- Cord length: 8' (244cm)
- Global multi-plug adapter available

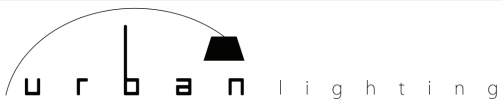

# DIMENSIONS

## CLAMP

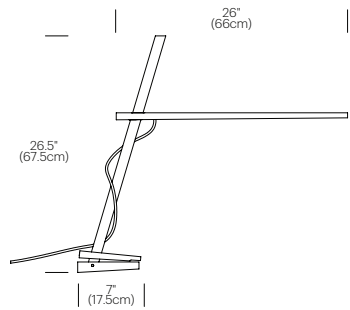

## CLAMP FREESTANDING

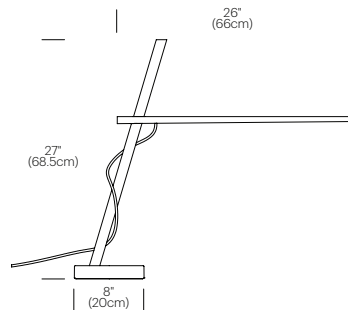

## CLAMP MINI

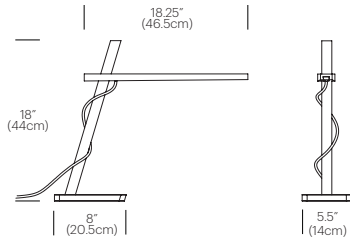

## CLAMP FLOOR

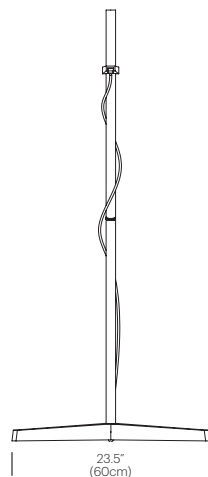
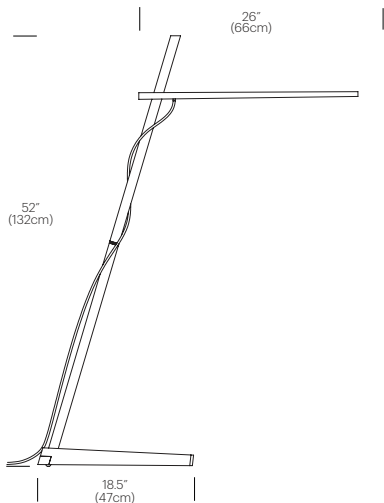

# FINISH OPTIONS

## CLAMP



White Oak /  
Red



Walnut /  
Black

## FREESTANDING BASE



White

